

Introduction

The ISL28470EVAL1Z evaluation board is a design platform containing all the circuitry needed to characterize critical performance parameters of the ISL28470 Quad Instrumentation Amplifier using a variety of user defined test circuits.

The ISL28470 is a quad channel instrumentation amplifier optimized for 2.4V to 5V single supplies. The device features an Input Range Enhancement Circuit (IREC) which maintains CMRR performance for input voltages equal to the positive supply and down to 50mV above the negative supply rail. The input signal is capable of swinging above the positive supply rail and to the negative supply with only a slight degradation of the CMRR performance. The output operation is rail to rail. The ISL28270 is compensated for a minimum gain of 100.

Reference Documents

- ISL28470 Data Sheet, FN6260

Evaluation Board Key Features

The ISL28470EVAL1Z is designed to be operated from a single supply (+2.4VDC to +5VDC), or from split supplies (± 1.2 VDC to ± 2.5 V). The board is configured for 4 independent instrumentation amplifiers connected for a closed loop gain of 101 with inverting and non-inverting high impedance terminated with 100k resistors to ground. Each amplifier contains it's own VREF input to establish an input common mode reference. An ENABLE select switch is provided for each amplifier to be used to save power by powering the device down.

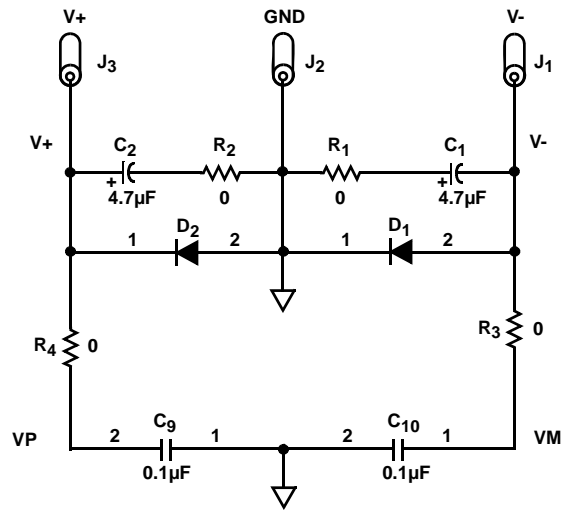

FIGURE 1. POWER SUPPLY CIRCUIT

Power Supplies (Refer to Figure 1)

External power connections are made through the +V, -V and Ground connections on the evaluation board. For single supply operation, the -V and Ground pins are tied together to the power supply negative terminal. For split supplies, +V and -V terminals connect to their respective power supply terminals. De-coupling capacitors, C1 and C2, connect to ground through R1 and R2, 0Ω resistors. Resistors R3 and R4 are 0Ω but can be changed by the user to provide power supply filtering, or to reduce the voltage rate-of-rise to less than ± 1 V/µs. Anti-reverse diodes D1 and D2 protect the circuit in the case of accidental polarity reversal.

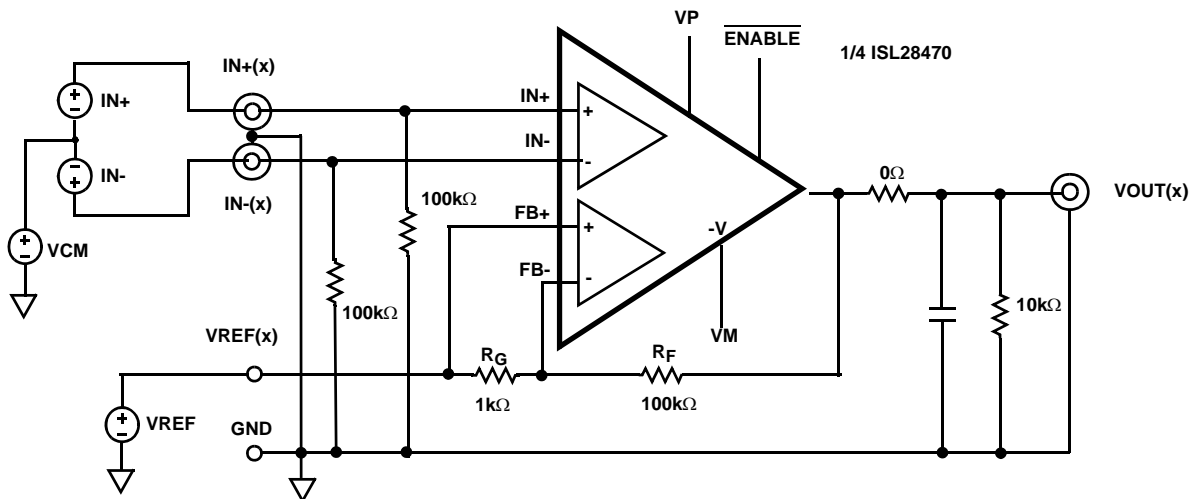
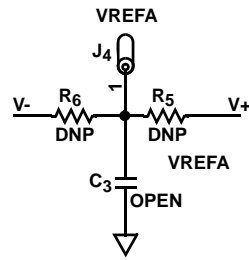

FIGURE 2. BASIC AMPLIFIER CONFIGURATION

Amplifier Configuration (Figure 2)

The schematic of each of the 4 Op Amps with the components supplied is shown in Figure 2. The circuit implements a differential input instrumentation amp with a closed loop gain of 101. The circuit can operate from a single 2.4VDC to +5VDC supply, or from dual supplies from ± 1.2 VDC to ± 2.5 VDC. The output common mode reference is applied to the VREF pin, and has a range from ground (VM) to VP.



User-selectable Options (Figure 3)

Component pads are included to enable a variety of user-selectable circuits to be added to the amplifier differential inputs, the VREF input, and the amplifier feedback loop. A voltage divider and filter option can be added to establish a power supply tracking common mode reference at the VREF input, or a coaxial connection to the ISL28470 FB+ pin can be made at the FB+ BNC connector. The differential inputs have additional resistor placements for adding input attenuation, or to establish input DC offsets through the VREF pin.

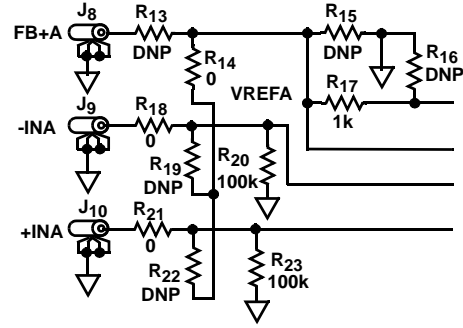
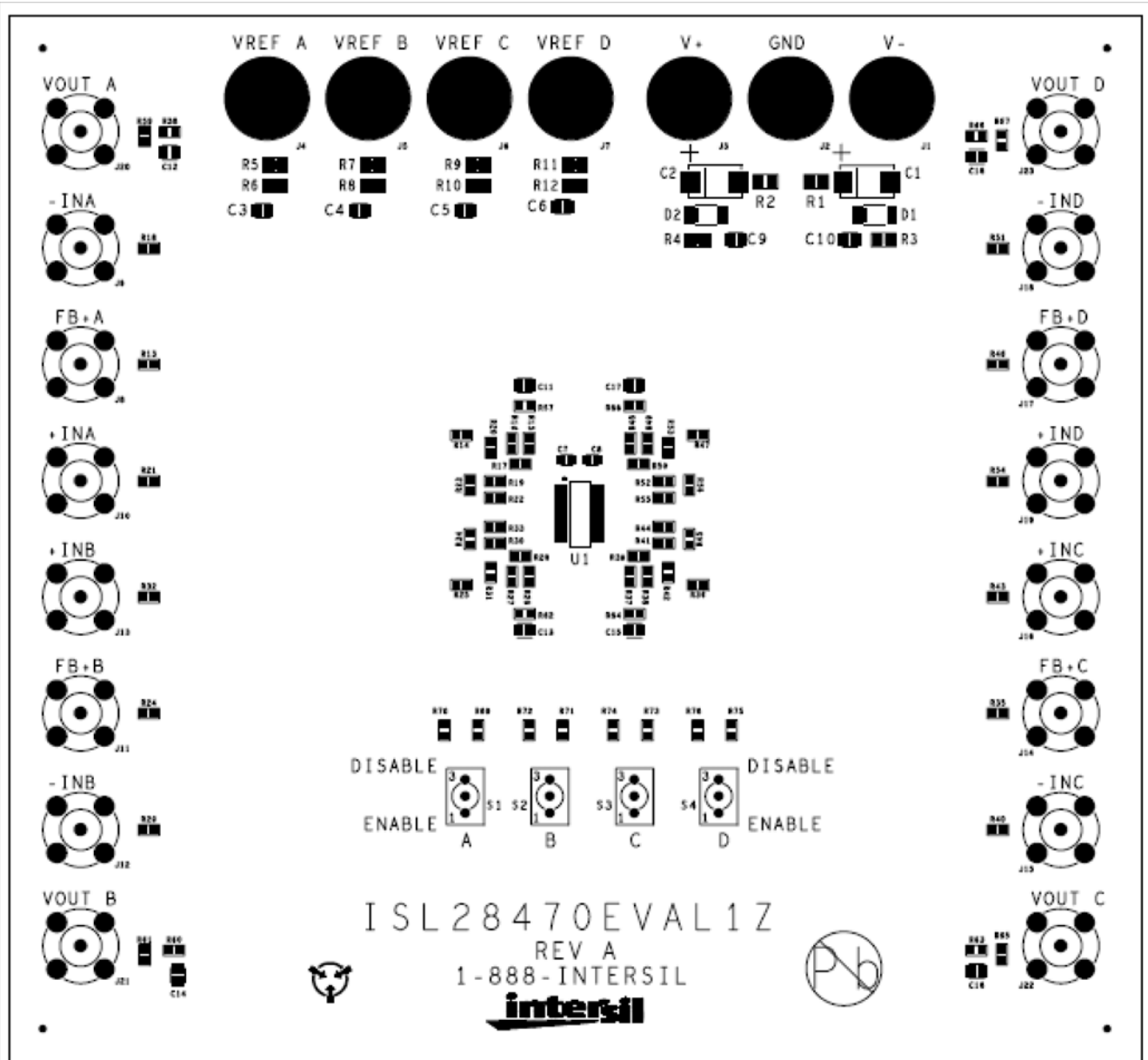

FIGURE 3. COMPONENT-SELECTABLE OPTIONS

ISL28470EVAL1Z Components Parts List

DEVICE #	DESCRIPTION	COMMENTS
C ₁ , C ₂	CAP-TANTALUM, SMD, D,4.7 μ F, 50V, 10%, LOW ESR, ROHS	Power Supply Decoupling
C ₇ , C ₈	CAP, SMD, 0603, 0.01 μ F, 25V, 10%, X7R, ROHS	Power Supply Decoupling
C ₉ , C ₁₀	CAP, SMD, 0805, 0.1 μ F, 25V,10%, X7R, ROHS	Power Supply Decoupling
C ₃ -C ₆	CAP, SMD, 0805, DNP-PLACE HOLDER, ROHS	Optional VREF Filter Not Populated
C ₁₁ -C ₁₈	CAP, SMD, 0805, DNP-PLACE HOLDER, ROHS	Optional Amplifier Feedback Caps Not Populated
D ₁ , D ₂	DIODE-RECTIFIER, SMD, MELF, 2 Ld, 50V, 1A, GPP, ROHS	Reverse Power Protection
U1	ISL28470FAZIC INSTRUMENTATION AMP, 28P, QSOP, ROHS	
R ₁₃ , R ₁₄ -R ₁₆ , R ₁₉ , R ₂₂ , R ₂₄ -R ₂₇ , R ₃₀ , R ₃₃ , R ₃₅ -R ₃₈ , R ₄₁ , R ₄₄ , R ₄₆ -R ₄₉ , R ₅₂ , R ₅₅ , R ₆₉ , R ₇₁ , R ₇₃ , R ₇₅	RESISTOR, SMD, 0603, 0.1%, MF, DNP-PLACE HOLDER	User Selectable Resistors Not Populated
R ₁₈ , R ₂₁ , R ₂₉ , R ₃₂ , R ₄₀ , R ₄₃ , R ₅₁ , R ₅₄ , R ₅₈ , R ₆₀ , R ₆₃ , R ₆₆	RES, SMD, 0603, 0 Ω , 1/16W, TF, ROHS	0 Ω User Selectable Resistors
R ₁₇ , R ₂₈ , R ₃₉ , R ₅₀	RES, SMD, 0603, 1k, 1/10W, 1%, TF, ROHS	R _G Gain Resistors
R ₅₉ , R ₆₁ , R ₆₅ , R ₆₇ , R ₇₀ , R ₇₂ , R ₇₄ , R ₇₆	RES, SMD, 0603, 10k, 1/10W, 1%, TF, ROHS	
R ₂₀ , R ₂₃ , R ₃₁ , R ₃₄ , R ₄₂ , R ₄₅ , R ₅₃ , R ₅₆ , R ₅₇ , R ₆₂ , R ₆₄ , R ₆₈	RES, SMD, 0603, 100k, 1/10W, 1%, TF, ROHS	R _F Gain Resistors
R ₁ -R ₄	RES, SMD, 0805, 0 Ω , 1/8W, TF, ROHS	0 Ω User Selectable Resistors
R ₅ -R ₁₂	RES, SMD, 0805, DNP-PLACE HOLDER, ROHS	User Selectable Resistors Not Populated
S ₁ -S ₄	SWITCH-SEALED MINI TOGGLE, TH, 3P, SP, ON/NONE/ON, GOLD	Enable/Disable Select Switches

ISL28470EVAL1Z Top View



ISL28470EVAL1Z Schematic Diagram

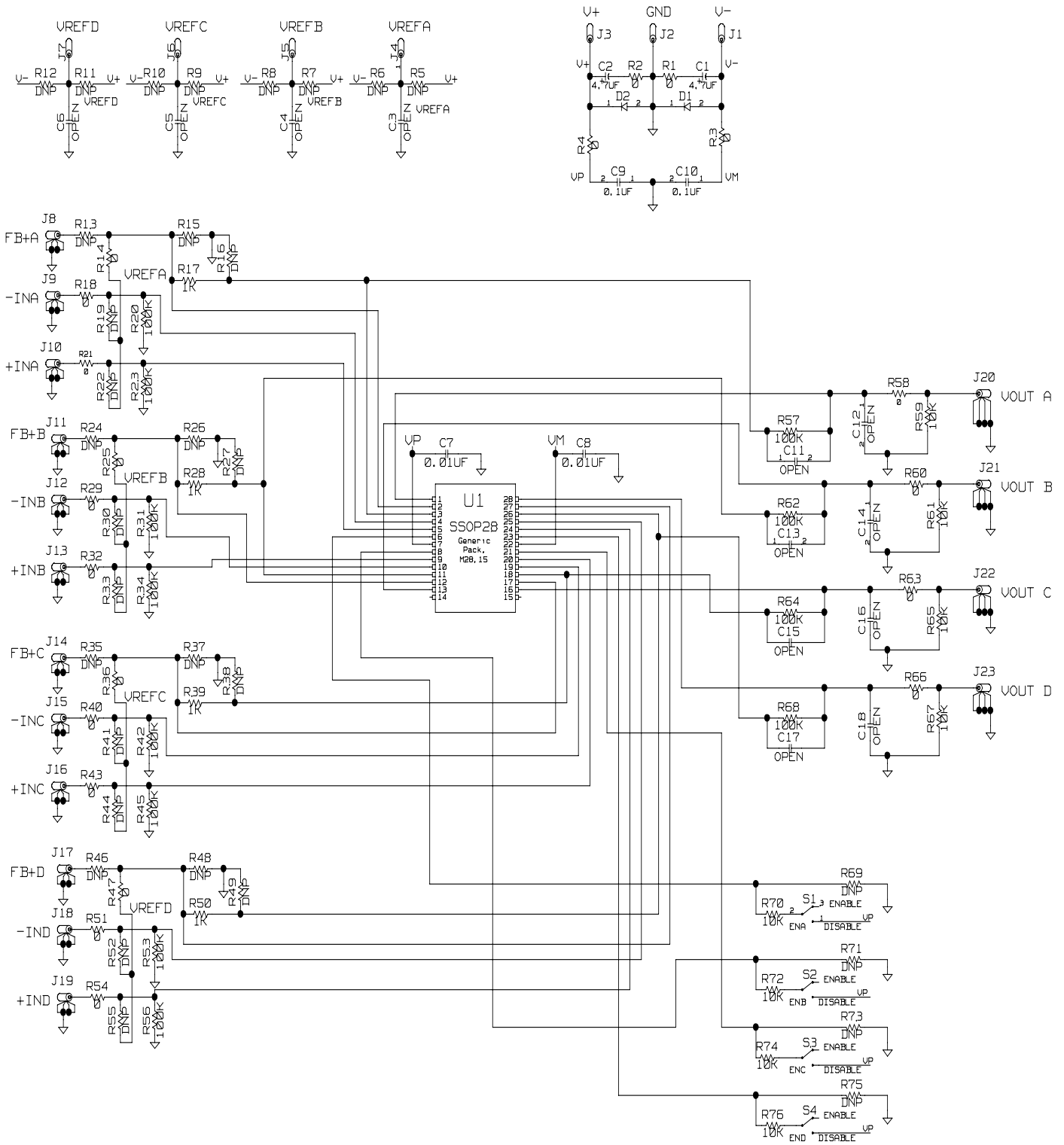

Intersil Corporation reserves the right to make changes in circuit design, software and/or specifications at any time without notice. Accordingly, the reader is cautioned to verify that the Application Note or Technical Brief is current before proceeding.

For information regarding Intersil Corporation and its products, see www.intersil.com